

50W Coaxial Attenuator DC-3GHz

Application

- ▶ Wireless communication system.
- ▶ Testing and measuring equipment.
- ▶ Radar and satellite systems.
- ▶ Military, Space and Commercial applications.

RF Characteristics

Part Number	Frequency range	Power	Attenuation Value	Attenuation Tolerance	VSWR Max
5o205003N1	DC-3GHz	50W	1 dB	±0.5 dB	1.2
5o205003N2			2 dB	±0.5 dB	1.2
5o205003N3			3 dB	±0.5 dB	1.2
5o205003N5			5 dB	±0.5 dB	1.2
5o205003N6			6 dB	±0.5 dB	1.2
5o205003N10			10 dB	±0.6 dB	1.2
5o205003N20			20 dB	±0.8 dB	1.2
5o205003N30			30 dB	±0.8 dB	1.2
5o205003N40			40 dB	±1.0 dB	1.2
5o205003N60			60 dB	±1.5 dB	1.2

Basic Specifications

Impedance	50Ω	Connector Type	N Male to Female
Power	50W	Storage Temperature	-55~+125°C

Overall Dimension(mm)

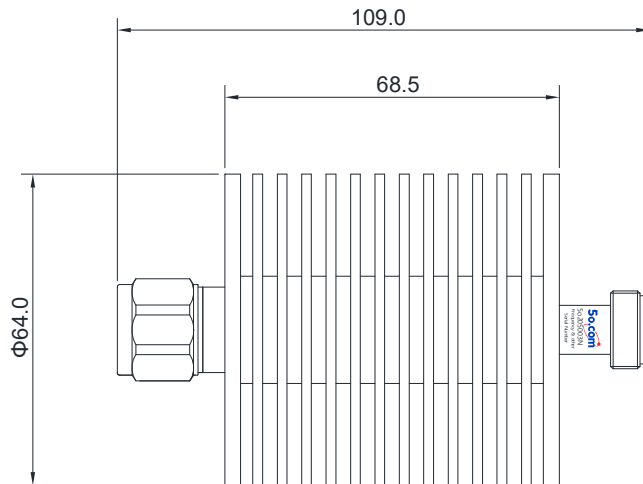

Tolerances: ±2% unless otherwise stated.

Power Derating Diagram

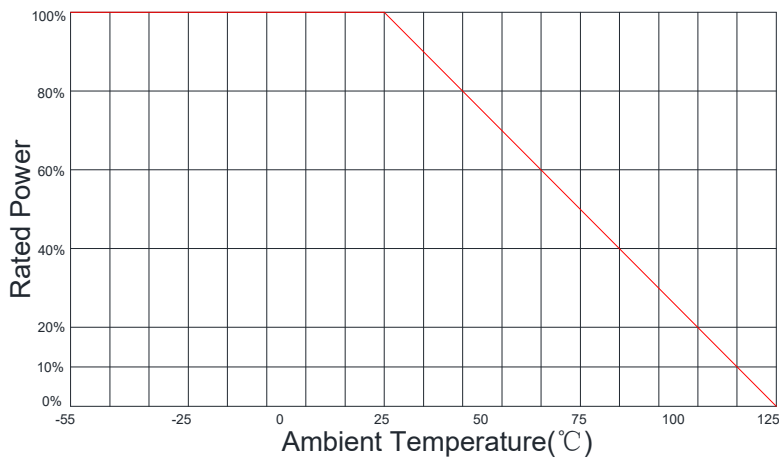

Notes

- ◆ Coaxial attenuator impedance matched to 50Ω.
- ◆ If necessary, the product shall be air-cooled for auxiliary heat dissipation.
- ◆ For products with a power of over 50W, pay attention to the direction during use and strictly avoid reverse connection.
- ◆ Custom design is available upon request.
- ◆ It supports a one-year standard warranty.