

100W Coaxial Attenuator DC-6GHz

Application

► Wireless communication system.

► Testing and measuring equipment.

► Radar and satellite systems.

► Military, Space and Commercial applications.

RF Characteristics

Part Number	Frequency range	Power	Attenuation Value	Attenuation Tolerance	VSWR Max
5o2010006N3	DC-6GHz	100W	3 dB	±0.6 dB	1.3
5o2010006N5			5 dB	±0.6 dB	1.3
5o2010006N6			6 dB	±0.8 dB	1.3
5o2010006N10			10 dB	±1.0 dB	1.3
5o2010006N20			20 dB	±1.5 dB	1.3
5o2010006N30			30 dB	±1.5 dB	1.3
5o2010006N40			40 dB	±1.5 dB	1.3
5o2010006N50			50 dB	±2.5 dB	1.35
5o2010006N60			60 dB	±3.0 dB	1.35

Basic Specifications

Impedance	50Ω	Connector Type	N Male to Female
Power	100W	Storage Temperature	-55~+125°C

Overall Dimension(mm)

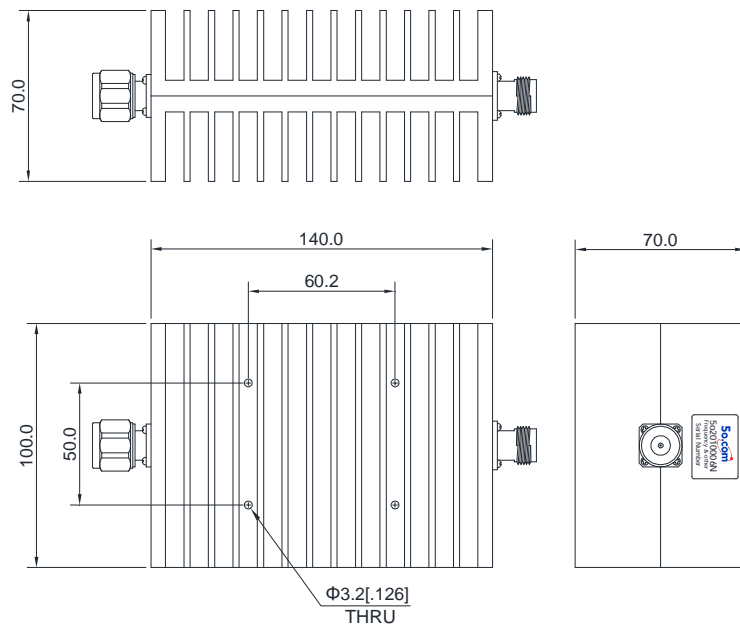

Tolerances: ±2% unless otherwise stated.

Power Derating Diagram

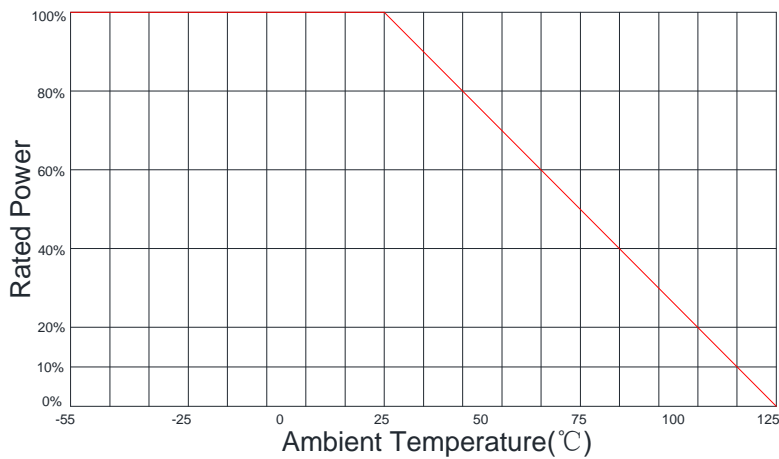

Notes

- ◆ Coaxial attenuator impedance matched to 50Ω.
- ◆ If necessary, the product shall be air-cooled for auxiliary heat dissipation.
- ◆ For products with a power of over 50W, pay attention to the direction during use and strictly avoid reverse connection.
- ◆ Custom design is available upon request.
- ◆ It supports a one-year standard warranty.